

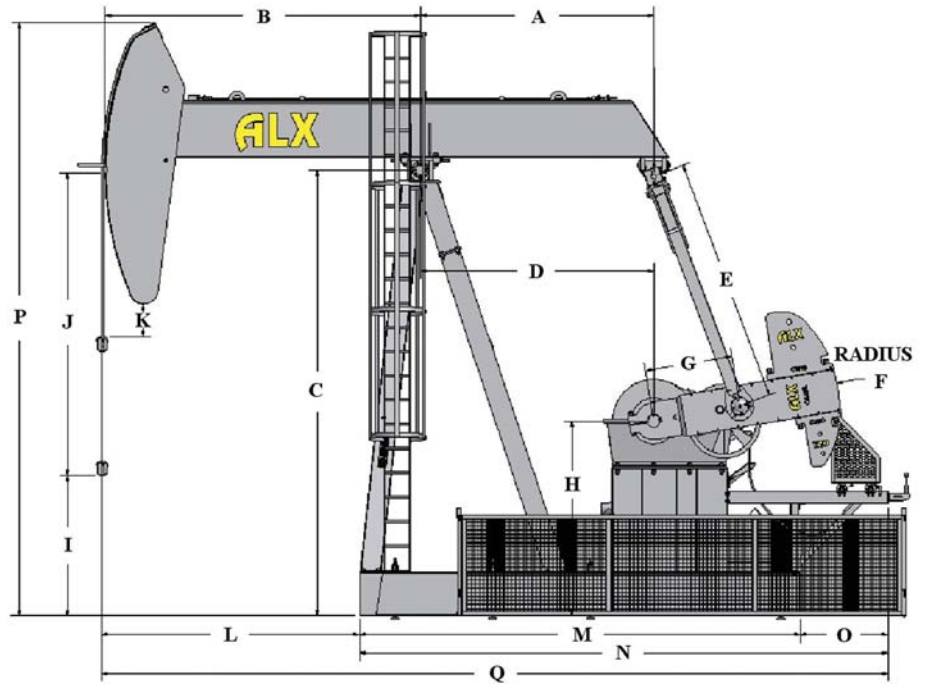

Pumping Unit 114-173-64



GENERAL DIMENSIONS

A	B	C	D	E	F	G	H	I	J	K	L	M	N	O	P	Q	Back Width	Front Width	Overall Width
85	82.5	160	85	91.5	61	32	66	89.94	70.00	26.62	55.75	179.00	209.75	30.50	204	265.50	24	72.00	76.00

EFFECTIVE COUNTERBALANCE DATA

Weight	Combination	Counter Balance Effect
	Crank Only	3094
2	#13	5579
2	#15	7509
4	#13	8064
2	#16	9000
2	#13 + #15	9994
2	#13 + #16	11485
4	#15	11923
2	#15 + #16	13415

Counter Weights	Weight	Crank Arm	Weight
#13	738 lbs	R32	1640 lbs
#15	1494 lbs		
#16	2100 lbs		

GENERAL ENGINEERING DATA

Peak Torque Rating, API	114,000 in-lbs
Polish Rod Capacity	17,300 lbs
Stroke Lengths	64", 53", 43"
Walking Beam Size	21" @ 62 lbs
Reducer Model	C114
Reducer Ratio	30.52
Input Shaft Size	2.250
Max. Sheave Diameter	30"-4C
Belts for Std High Mount	C173
Oil Capacity	85L
Structural Unbalance	520 lbs
Gear Box Weight	4975 lbs
Total Weight	*15670 lbs

*Not including counter weight

STANDARD EQUIPMENT

- High Mount Assembly
- Bendix Style Brake
- Mesh Crank Arm Guards
- Bridle Assembly
- Single Rail Tie Down Bars
- Adjustable Motor Rails

- 2 Ladders With Safety Cages
- Cable Fall Restraint
- Wrist Pin Wrench
- Gear Box Oil Fill
- T Bolts
- Painted Black & Safety Yellow

OPTIONAL EQUIPMENT

- Counter Balance Weights
- Electric Motors
- Triple Rated Electric Motors
- Low Oil Level Switch
- Full Belt Guard With Mesh
- Fiberglass Full Belt Guard
- Concrete Bases
- Colour Options
- Low Mount Brake Cables

- Low Mount Engine Rails
- Drive Sheave & Bolts
- Vibration Switches
- Central Lubrication
- Full Belt Guard Enclosed
- Partial Belt Guard
- Pressure Treated Stripping
- Low Mount Brake Mount
- Speciality Lube Oils

CONSTRUCTION FEATURES

- Manufactured To API 11E Specifications
- ISO/Q1 Approved Fabrication Plant
- CWB Welded To W48
- Mono Gear Box Mounting Plate
- Three Leg Sampson Post - Removable Third Leg
- Saddle Bearing - Single 6" x 11" Railroad Style

- Split Case Gear Boxes
- Replaceable Wrist Pin Sleeves
- Hangar Style Rear Equalizer
- Pitman Arm Utilize Brass Bearings For Quiet Operation
- Common Off The Shelf Bearings and Seals



WATERFLOOD ALX PUMPING UNITS

Please Call for Quote:

ALX Canada Sales 1-306-634-7212
 ALX USA Sales 1-501-860-3277
 ALX Plant - 1-306-634-7212 or Fax - 1-306-634-7887

Address:

ALX
 Box 1490
 Estevan, Sk
 S4A 2L7

ALX
 130 Perkins St.
 Estevan, Sk
 S4A 0C3



GET PUMPED UP AT WWW.WATERFLOOD.COM