

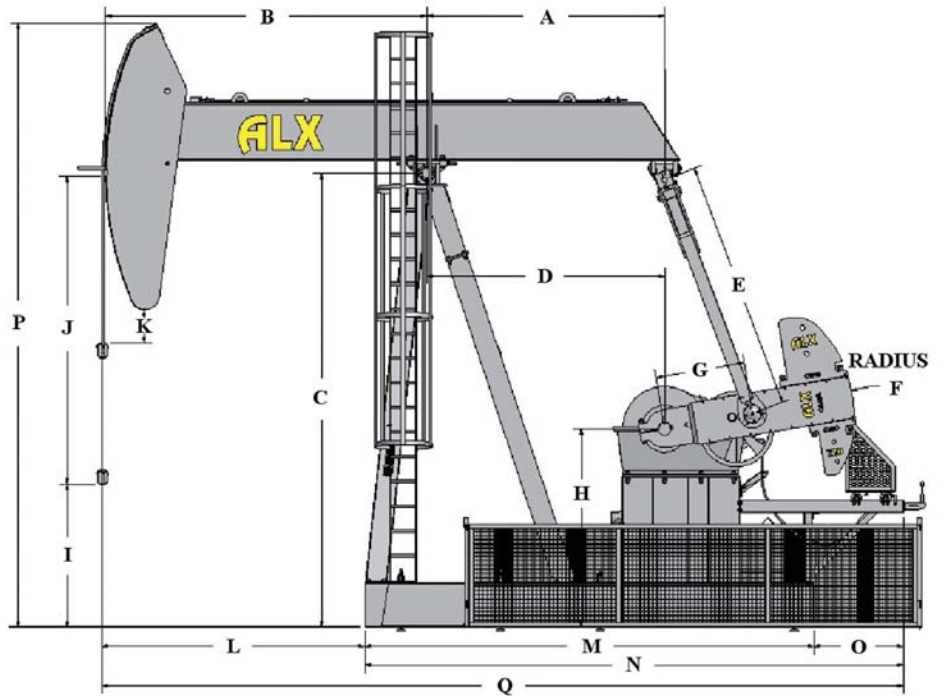

Pumping Unit 160-173-100



GENERAL DIMENSIONS

A	B	C	D	E	F	G	H	I	J	K	L	M	N	O	P	Q	Back Width	Front Width	Overall Width
98.50	129.00	191.50	98.5	110.75	76.00	37.00	78.00	60.00	100.00	15.25	102.25	193.75	236.75	43.00	254.75	339.25	27.25	72.00	77.25

EFFECTIVE COUNTERBALANCE DATA

Weight	Combination	Counter Balance Effect
	Crank Only	3601
2	#13	5567
2	#15	7187
4	#13	7534
2	#16	8449
2	#13 + #15	9153
2	#13 + #16	10416
4	#15	10773
2	#15 + #16	12036
4	#16	13298

GENERAL ENGINEERING DATA

Peak Torque Rating, API	160,000 in-lbs
Polish Rod Capacity	17,300 lbs
Stroke Lengths	100", 85", 72"
Walking Beam Size	24" @ 117 lbs
Reducer Model	C160
Reducer Ratio	30.52
Input Shaft Size	2,500
Max. Sheave Diameter	36"-4C
Belts for Std High Mount	C195
Oil Capacity	105L
Structural Unbalance	-287 lbs
Gear Box Weight	6091 lbs
Total Weight	*22361 lbs

*Not including counter weight

Counter Weights	Weight	Crank Arm	Weight
#13	738 lbs	R32	2040 lbs
#15	1494 lbs		
#16	2100 lbs		

STANDARD EQUIPMENT

- High Mount Assembly
- Bendix Style Brake
- Mesh Crank Arm Guards
- Bridle Assembly
- Single Rail Tie Down Bars
- Adjustable Motor Rails

- 2 Ladders With Safety Cages
- Cable Fall Restraint
- Wrist Pin Wrench
- Gear Box Oil Fill
- T Bolts
- Painted Black & Safety Yellow

OPTIONAL EQUIPMENT

- Counter Balance Weights
- Electric Motors
- Triple Rated Electric Motors
- Low Oil Level Switch
- Full Belt Guard With Mesh
- Fiberglass Full Belt Guard
- Concrete Bases
- Colour Options
- Low Mount Brake Cables

- Low Mount Engine Rails
- Drive Sheave & Bolts
- Vibration Switches
- Central Lubrication
- Full Belt Guard Enclosed
- Partial Belt Guard
- Pressure Treated Stripping
- Low Mount Brake Mount
- Speciality Lube Oils

CONSTRUCTION FEATURES

- Manufactured To API 11E Specifications
- ISO/Q1 Approved Fabrication Plant
- CWB Welded To W48
- Mono Gear Box Mounting Plate
- Three Leg Sampson Post - Removable Third Leg
- Saddle Bearing - Double 6" x 11" Railroad Style

- Split Case Gear Boxes
- Replaceable Wrist Pin Sleeves
- Hangar Style Rear Equalizer
- Pitman Arm Utilize Brass Bearings For Quiet Operation
- Common Off The Shelf Bearings and Seals



WATERFLOOD ALX PUMPING UNITS

Please Call for Quote:

ALX Canada Sales 1-306-634-7212
 ALX USA Sales 1-501-860-3277
 ALX Plant - 1-306-634-7212 or Fax - 1-306-634-7887

Address:

ALX
 Box 1490
 Estevan, Sk
 S4A 2L7



ALX
 130 Perkins St.
 Estevan, Sk
 S4A 0C3



GET PUMPED UP AT WWW.WATERFLOOD.COM