

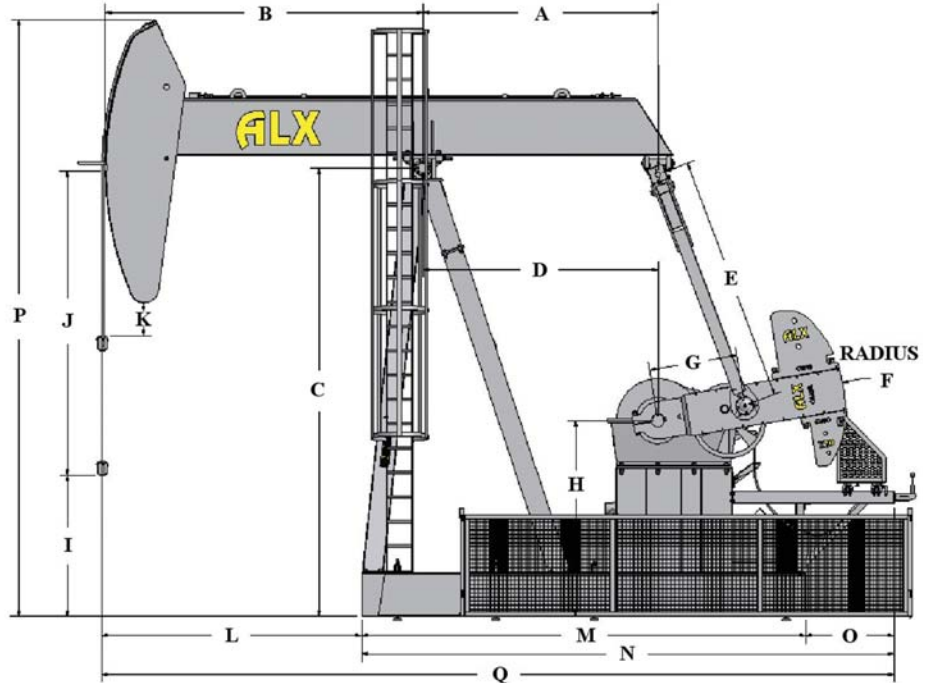

# Pumping Unit 320-256-120



## GENERAL DIMENSIONS

A	B	C	D	E	F	G	H	I	J	K	L	M	N	O	P	Q	Back Width	Front Width	Overall Width
114.50	155.00	215.50	114.50	118.75	92.00	43.00	94.00	67.75	120.00	16.00	125.50	216.00	259.75	43.00	286.50	385.00	32.50	72.00	83.00

## EFFECTIVE COUNTERBALANCE DATA

Weight	Combination	Counter Balance Effect
	Crank Only	5761
2	#13	7819
2	#15	9597
4	#13	9877
2	#16	10992
2	#13 + #15	11655
2	#13 + #16	13050
4	#15	13432
2	#17	13891
2	#15 + #16	14828
2	#13 + #17	15949
4	#16	16223
2	#15 + #17	17727
2	#16 + #17	19122
4	#17	22021

## GENERAL ENGINEERING DATA

Peak Torque Rating, API	320,000 in-lbs
Polish Rod Capacity	25,600 lbs
Stroke Lengths	120", 105", 90"
Walking Beam Size	27" @ 146
Reducer Model	C320
Reducer Ratio	29.32
Input Shaft Size	3.000
Max. Sheave Diameter	36"-5C
Belts for Std High Mount	C195
Oil Capacity	140L
Structural Unbalance	-301 lbs
Gear Box Weight	10210 lbs
Total Weight	*32225 lbs

\*Not including counter weight

Counter Weights	Weight	Crank Arm	Weight
#13	738 lbs	R43	3500 lbs
#15	1494 lbs		
#16	2100 lbs		
#17	3500 lbs		

**STANDARD EQUIPMENT**

- High Mount Assembly
- Bendix Style Brake
- Mesh Crank Arm Guards
- Bridle Assembly
- Single Rail Tie Down Bars
- Adjustable Motor Rails

- 2 Ladders With Safety Cages
- Cable Fall Restraint
- Wrist Pin Wrench
- Gear Oil Fill
- T Bolts
- Painted Black & Safety Yellow

**OPTIONAL EQUIPMENT**

- Counter Balance Weights
- Electric Motors
- Triple Rated Electric Motors
- Low Oil Level Switch
- Full Guard With Mesh
- Fiberglass Full Guard
- Concrete Bases
- Colour Options
- Low Mount Brake Cables

- Low Mount Engine Rails
- Drive Sheave & Bolts
- Vibration Switches
- Central Lubrication
- Full Guard Enclosed
- Partial Belt Guard
- Pressure Treated Stripping
- Low Mount Brake Mount
- Speciality Lube Oils

**CONSTRUCTION FEATURES**

- Manufactured To API 11E Specifications
- ISO/Q1 Approved Fabrication Plant
- CWB Welded To W48
- Mono Gear Box Mounting Plate
- Three Leg Sampson Post - Removable Third Leg
- Saddle Bearing - Double 6" x 11" Railroad Style

- Split Case Gear Boxes
- Replaceable Wrist Pin Sleeves
- Hangar Style Rear Equalizer
- Pitman Arm Utilize Brass Bearings For Quiet Operation
- Common Off The Shelf Bearings and Seals



**WATERFLOOD ALX PUMPING UNITS**

Please Call for Quote:

ALX Canada Sales 1-306-634-7212  
 ALX USA Sales 1-501-860-3277  
 ALX Plant - 1-306-634-7212 or Fax - 1-306-634-7887

Address:

ALX  
 Box 1490  
 Estevan, Sk  
 S4A 2L7



ALX  
 130 Perkins St.  
 Estevan, Sk  
 S4A 0C3



**GET PUMPED UP AT WWW.WATERFLOOD.COM**